

G4 Digital DC Input Modules

Features

- 4000 volts transient optical isolation
- Built-in LED status indicator
- Small footprint design, reducing mounting space by approximately 50 percent
- Built-in filtering for transient suppression and noise rejection
- Operating temperature: -30 °C to 70 °C
- UL recognized, CSA certified, CE approved
- Passes NEMA Showering Arc Test (ICS 2-230)
- Meets IEEE Surge Withstand Specification (IEEE-472)

Description

Opto 22's G4 DC input modules are used to detect on/off DC voltage levels. Each module provides up to 4000 volts (transient) of optical isolation between field inputs and the logic output of the circuit.

All DC input modules except the G4IDC5K and G4IDC5D are designed with filtering on the input and a hysteresis amplifier, providing high noise rejection and transient-free, "clean" switching. The G4IDC5K is a fast-switching module used to detect signals produced by photoelectric switches and TTL devices. The low-cost G4IDC5D is used for data acquisition.

The G4IDC5MA is a special module featuring a manual-on/manual-off/automatic switch, ideal for diagnostic testing of control applications.

The G4IDC5-SW and G4IDC5-SWNC modules supply power to an external dry contact switch and sense switch closure (SW) or opening (SWNC).

Typical applications for DC input modules include sensing the presence or absence of voltage and sensing contact closure from sources such as proximity switches, limit switches, selector switches, push buttons, photoelectric switches, and TTL-compatible devices.



Opto 22 G4 digital input modules include the G4IDC5B high-speed module and the G4IDC5MA module with manual-on/manual-off/automatic switch for diagnostic testing.

Part Numbers

Part	Description
G4IDC5	G4 DC Input 10–32 VDC, 5 VDC Logic
G4IDC5B	G4 DC Input 4–16 VDC, 5 VDC Logic High Speed
G4IDC5D	G4 DC Input 2.5–28 VDC, 5 VDC Logic
G4IDC5G	G4 DC Input 35–60 VDC, 5 VDC Logic
G4IDC5K	G4 DC Input 2.5–16 VDC, 5 VDC Logic Very High Speed
G4IDC5MA	G4 DC Input 10–32 VDC, 5 VDC Logic With Manual/Auto Switch
G4IDC5-SW	G4 Switch Status Input, Self-powered, Normally Open
G4IDC5-SWNC	G4 Switch Status Input, Self-powered, Normally Closed
G4IDC15	G4 DC Input 10–32 VDC, 15 VDC Logic
G4IDC24	G4 DC Input 10–32 VDC, 24 VDC Logic

G4 Digital DC Input Modules

Specifications

	Units	G4IDC5	G4IDC5B	G4IDC5D	G4IDC5G
Input voltage range	VDC VAC	10–32 12–32	4–16 4–16	2.5–28 —	35–60 35–60
Key feature		—	Higher speed	High speed	—
Input current at maximum line	mA	25	45	30	6
Isolation, input-to-output (transient):					
1 ms	V	4000	4000	4000	4000
1 minute	V	1500	1500	1500	1500
Turn-on time	ms	5	0.05	1	10
Turn-off time	ms	5	0.1	1.5	10
Input allowed for off-state	mA, V	1, 3	0.7, 1	0.2, 1	0.7, 7
Nominal output supply voltage	VDC	5	5	5	5
Output supply voltage range	VDC	4.5–6	4.5–6	4.5–6	4.5–6
Output supply current at nominal logic voltage	mA	12	12	12	12
Input resistance (R1 in schematic)	ohms	1.5 K	300	900	10 K
Control resistance (Rc in schematic)	ohms	220	220	470	220
Output voltage drop	V @ 50 mA	0.4	0.4	0.4	0.4
Output current (sinking)	mA	50	50	50	50
Output leakage with no input	microamps @ 30 VDC	100	100	10	100
Transistor	V breakdown	30	30	30	30
Temperature:					
Operating	°C	–30 to +70	–30 to +70	–30 to +70	–30 to +70
Storage	°C	–30 to +85	–30 to +85	–30 to +85	–30 to +85

G4IDC5-SW and G4IDC5-SWNC modules

See [page 4](#) for specifications and other information for the G4IDC5-SW and G4IDC5-SWNC self-powered modules. Schematic drawings for these modules appear on page 5.

G4 Digital DC Input Modules

Specifications (cont.)

	Units	G4IDC5K	G4IDC5MA	G4IDC15	G4IDC24
Input voltage range	VDC VAC	2.5–16 —	10–32 12–32	10–32 12–32	10–32 12–32
Key feature		Highest speed	Diagnostic switch	—	—
Input current at maximum line	mA	30	25	25	25
Isolation, input-to-output (transient):					
1 ms	V	4000	4000	4000	4000
1 minute	V	1500	1500	1500	1500
Turn-on time	ms	0.025*	5	5	5
Turn-off time	ms	0.025*	5	5	5
Input allowed for off-state	mA, V	0.2, 1	1, 3	1, 3	1,3
Nominal output supply voltage	VDC	5	5	15	24
Output supply voltage range	VDC	4.5–6	4.5–6	12–18	20–30
Output supply current at nominal logic voltage	mA	12	12	15	18
Input resistance (R1 in schematic)	ohms	500	1.5 K	1.5 K	1.5 K
Control resistance (Rc in schematic)	ohms	220	220	1 K	2.2 K
Output voltage drop	V @ 50 mA	0.4	0.4	0.4	0.4
Output current (sinking)	mA	50	50	50	50
Output leakage with no input	microamps @ 30 VDC	100	100	100	100
Transistor	V breakdown	30	30	30	30
Temperature:					
Operating	°C	–30 to +70	–30 to +70	–30 to +70	–30 to +70
Storage	°C	–30 to +85	–30 to +85	–30 to +85	–30 to +85

* At 5Vp-p square wave input, 50% duty cycle.

G4 Digital DC Input Modules

G4IDC5-SW and G4IDC5-SWNC Modules

Description

Each G4IDC5-SW and G4IDC5-SWNC module provides one isolated channel of contact status input. Each module supplies 13 volts of power to an external dry contact switch. The G4IDC5-SW senses switch closure; the G4IDC5-SWNC senses switch opening. Each user-supplied switch is connected with two wires. Because these modules include power for the switch, they are particularly cost-effective when labor costs for wiring external power are high.

Typical switches for use with these modules are switched status sensors (level sensors, pressure indicators, etc.), magnetic reed switches (used on doors or windows for burglar alarms), snap-action micro switches, the auxiliary switches on motor starters, and most relay contacts.

CAUTION: G4IDC5-SW and G4IDC5-SWNC inputs are not intended to be used with contacts that are connected to any external user-supplied voltage or currents.

Specifications

Field Side Ratings	
Open Circuit Voltage (Switch Open)	11 VDC min., 13 VDC typical, 15 VDC max.
Short Circuit Current (Switch Closed)	6 milliamps nominal
Minimum Off Resistance	≥20 K ohms
Maximum Allowable On Resistance (Wire + Contact Resistance)	500 ohms
Logic Side Ratings	
Logic Output Voltage for G4IDC5-SW (normally open)	<0.5 V max. (switch closed; LED on) @ 2 mA sinking 2.7 V min. (switch open; LED off) @ 0.4 mA sourcing
Logic Output Voltage for G4IDC5-SWNC (normally closed)	<0.5 V max. (switch open; LED on) @ 2 mA sinking 2.7 V min. (switch closed; LED off) @ 0.4 mA sourcing
Maximum Operating Common Mode Voltage (Field Term to Logic Connector)	250 V
Power Requirements:	5 VDC (±0.25) @ 25 mA nom.
Module Ratings	
Number of Channels Per Module	1
Turn-on Time	8 msec typical
Turn-off Time	8 msec typical
Input-to-output Isolation (transient)	4000 V AC/DC
Temperature	0 °C to 70 °C, operating -30 °C to 85 °C, storage

G4 Digital DC Input Modules

Dimensions

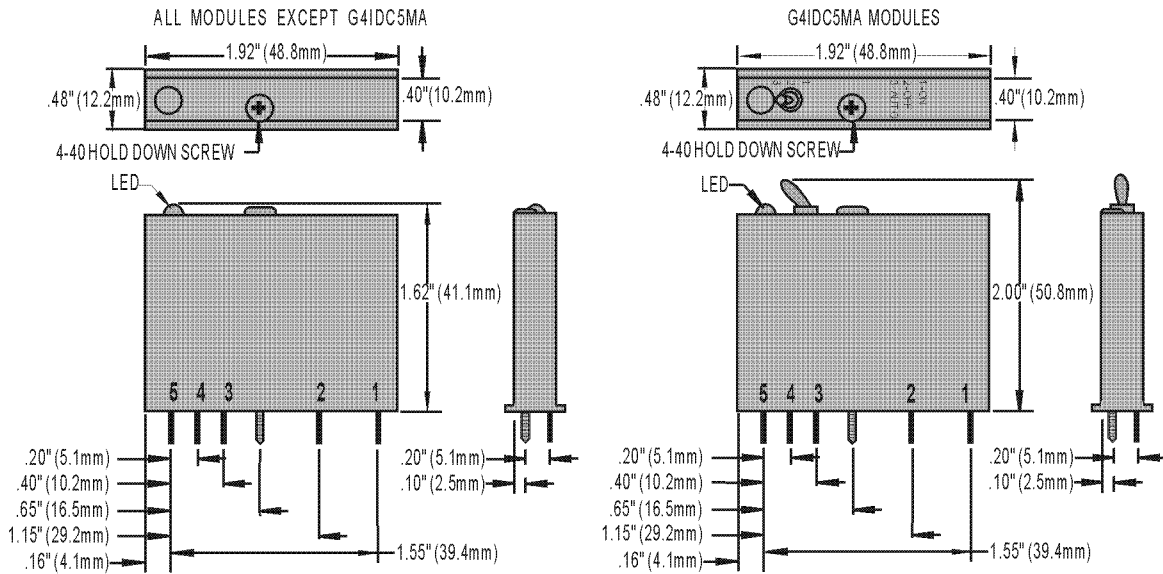

Schematics

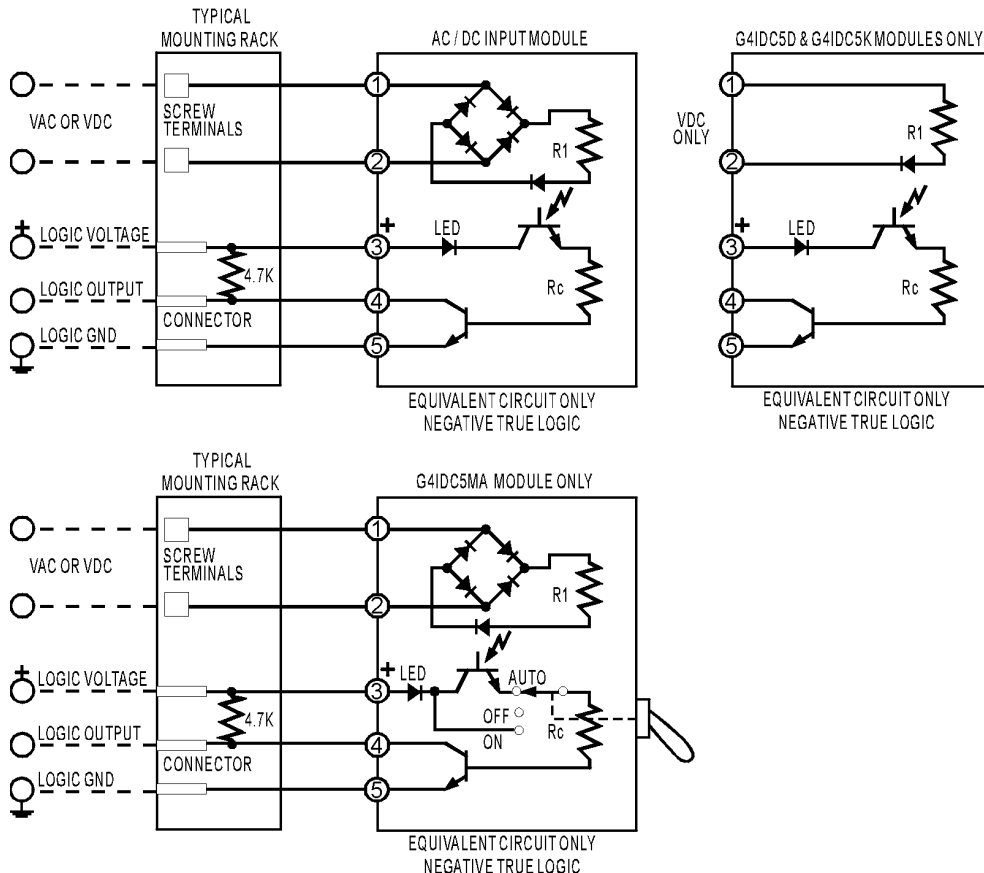

More About Opto 22

Products

Opto 22 develops and manufactures reliable, flexible, easy-to-use hardware and software products for industrial automation, energy management, remote monitoring, and data acquisition applications.

OptoEMU Energy Management System

The easy-to-use OptoEMU Sensor monitors electrical energy use in your facility and delivers detailed, real-time data you can see and analyze. The Sensor can monitor energy data from pulsing meters, electrical panels or subpanels, and equipment. View energy data online using a software service or incorporate the data into your control system for complete energy management.

SNAP PAC System

Designed to simplify the typically complex process of selecting and applying an automation system, the SNAP PAC System consists of four integrated components:

- SNAP PAC controllers
- PAC Project™ Software Suite
- SNAP PAC brains
- SNAP I/O™

SNAP PAC Controllers

Programmable automation controllers (PACs) are multifunctional, modular controllers based on open standards.

Opto 22 has been manufacturing PACs for over two decades. The standalone SNAP PAC S-series and the rack-mounted SNAP PAC R-series both handle a wide range of digital, analog, and serial functions for data collection, remote monitoring, process control, and discrete and hybrid manufacturing.

SNAP PACs are based on open Ethernet and Internet Protocol (IP) standards, so you can build or extend a system easily, without the expense and limitations of proprietary networks and protocols.

PAC Project Software Suite

Opto 22's PAC Project Software Suite provides full-featured, cost-effective control programming, HMI (human machine interface) development and runtime, OPC server, and database connectivity software for your SNAP PAC System.

Control programming includes both easy-to-learn flowcharts and optional scripting. Commands are in plain English; variables and I/O point names are fully descriptive.

PAC Project Basic offers control and HMI tools and is free for download on our website, www.opto22.com. PAC Project Professional, available for separate purchase, adds

OptoOPCServer, OptoDataLink, options for controller redundancy or segmented networking, and support for legacy Opto 22 serial *mistic*™ I/O units.

SNAP PAC Brains

While SNAP PAC controllers provide central control and data distribution, SNAP PAC brains provide distributed intelligence for I/O processing and communications. Brains offer analog, digital, and serial functions, including thermocouple linearization; PID loop control; and optional high-speed digital counting (up to 20 kHz), quadrature counting, TPO, and pulse generation and measurement.

SNAP I/O

I/O provides the local connection to sensors and equipment. Opto 22 SNAP I/O offers 1 to 32 points of reliable I/O per module, depending on the type of module and your needs.

Analog, digital, and serial modules are all mixed on the same mounting rack and controlled by the same processor (SNAP PAC brain or rack-mounted controller).

Quality

Founded in 1974, Opto 22 has established a worldwide reputation for high-quality products. All are made in the U.S.A. at our manufacturing facility in Temecula, California. Because we do no statistical testing and each part is tested twice before leaving our factory, we can guarantee most solid-state relays and optically isolated I/O modules for life.

Free Product Support

Opto 22's California-based Product Support Group offers free, comprehensive technical support for Opto 22 products. Our staff of support engineers represents decades of training and experience. Support is available in English and Spanish by phone or email, Monday–Friday, 7 a.m. to 5 p.m. PST.

Additional support is always available on our website: how-to videos, OptoKnowledgeBase, self-training guide, troubleshooting and user's guides, and OptoForums.

In addition, hands-on training is available for free at our Temecula, California headquarters, and you can [register online](#).

Purchasing Opto 22 Products

Opto 22 products are sold directly and through a worldwide network of distributors, partners, and system integrators. For more information, contact Opto 22 headquarters at 800-321-6786 or 951-695-3000, or visit our website at www.opto22.com.

www.opto22.com