

The N-TRON® 702-W Industrial Wireless Radio offers outstanding performance and ease of use. It is ideally suited for connecting wireless devices to a wired network or for connecting two wired networks where it is not possible, impractical, or too expensive to install cable.

## Product Features

- Full IEEE 802.11a,b,g,n Compliance
- One 10/100BaseTX RJ-45 Port
- Three Antennas for 3x3 MIMO Operations
- Four user definable LED's for display of signal quality
- Radio Enable, Link/Activity, and power LEDs
- 802.3af PoE Powered Device
- Extended Environmental Specifications
- Autosensing 10/100BaseTX, Duplex, and MDIX
- Rugged DIN Rail Enclosure
- Redundant Power Inputs (20-49 VDC)
- Web Browser Management

## Wireless Compliance:

- IEEE 802.11a Compliant
- IEEE 802.11b Compliant
- IEEE 802.11g Compliant
- IEEE 802.11n draft Compliant

## Security

- 802.11i with AES-CCM & TKIP Encryption
- 802.1x, 64/128 bit WEP

## Data Rates:

- Legacy 802.11a/b/g (1-54Mbps)
- 802.11n (up to 300Mbps)

## Range Performance:

- Indoor (Antenna Dependent) greater than 300m
- Outdoor (Antenna Dependent) greater than 60km

## Applications

In industrial environments, situations arise where the installation of fiber or Cat5e cable and associated power cables is difficult or cost prohibitive. There are also applications which require communications with mobile devices such as forklifts, cockpits on cranes, laptop computers, and other devices that are impossible to connect with copper or fiber cable. The N-TRON® 702-W provides a wireless connection that can be quickly and easily deployed. With it's wide operating temperature range and 1 million hour MTBF, the 702-W offers the industrial ruggedness that customers have come to expect of N-TRON products. Three antennas allows the 702-W to utilize Multiple In, Multiple Out (MIMO) technology for increased throughput. Power over Ethernet (PoE) technology enables the 702-W to receive power through Cat5e cable from a PoE sourcing device, such as the N-TRON 105TX-POE Switch or the 100-PoE4 Midspan. Temporary deployments of network nodes are much easier using wireless and PoE technology because only one Cat5e cable is required.



## Industrial Packaging and Specifications

The is specifically designed to operate in industrial environments. With it's rugged enclosure and industrial specifications such as extended shock and vibrations specs plus redundant power inputs, the 702-W easily meets and exceeds the operating parameters of the connected equipment.

## Multiple Wireless Modes

The 702-W provides a number of configuration options to allow it to be customized to suit specific application requirements.

**Station:** In "station" configuration the 702-W is used to connect a single device (MAC Address) to a wireless access point.

**Station, WDS (Wireless Distribution System):** In "station, WDS" mode the 702-W can be connected to a remote wired switch and will allow multiple devices (MAC Address forwarding) to be connected to the wireless access point with WDS activated.

**Access Point:** The "Access Point" mode allows the 702-W to serve as a wireless switch for the attached wireless stations. Wireless access points are commonly used to create one wireless local area network (WLAN) that spans an area around the Access Point. Each access point typically supports up to 253 stations.

**Access Point, WDS (Wireless Distribution System):** The 702-W in "Access Point, WDS" mode allows wireless connection of a number of access points to extend the coverage of the wireless network. The main base Access Point in WDS mode is extended using a series of relay access points in WDS mode (Extended Service Set) and can in turn form a WLAN consisting of thousands of stations. All stations should be configured in "Station WDS" mode. Correctly configured switches using WDS will create a single network, providing station mobility throughout the wireless network.

## Multiple Network Modes

**Bridge:** In this mode the 702-W will operate in layer two without network segmentation.

**Router:** Router operating mode offers layer three routing to allow network segmentation.

## Scenario 1 – Basic Bridge

### Access Point:

The "Access Point" mode allows the 702-W to serve as a wireless switch for the wireless stations attached to it. Wireless access points are commonly used to create one wireless local area network (WLAN) that spans an area around the Access Point. Each access point typically supports up to 253 stations.

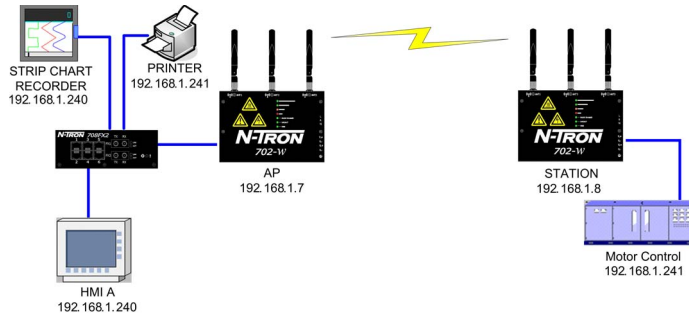

### Station:

In "station" configuration the 702-W is used to connect a single device (MAC Address) to a wireless access point.

For added security, the 702-W supports WEP, WPA™, and WPA2™. WPA and WPA2, TKIP (Temporal Key Integrity Protocol) and CCMP (Counter Mode with Cipher Block Chaining Message Authentication Code Protocol) are available.

## Scenario 2 – Control Network

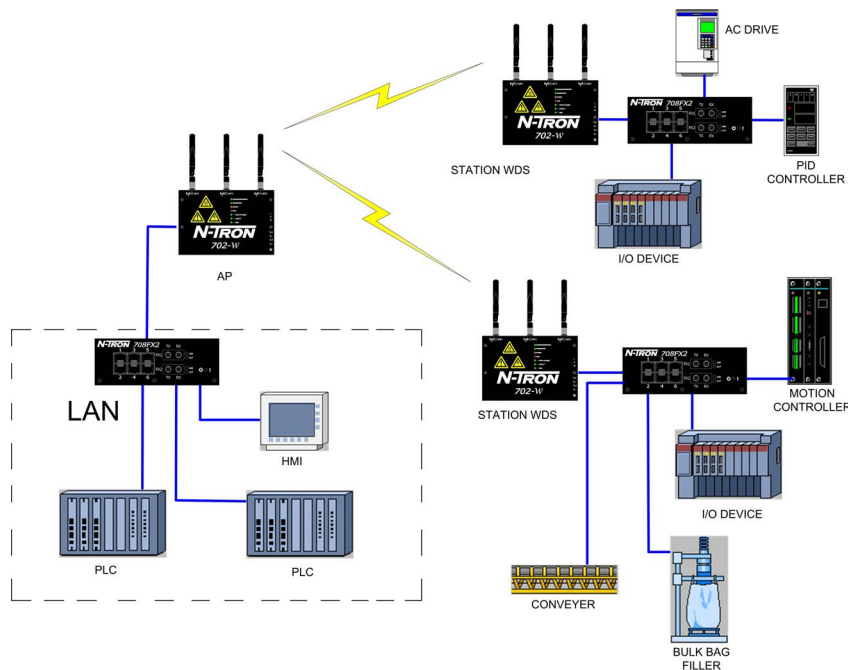

In Station WDS mode the 702-W can be connected to a remote wired Ethernet switch with multiple devices connected to the switch.

## Scenario 3 – WDS Peering

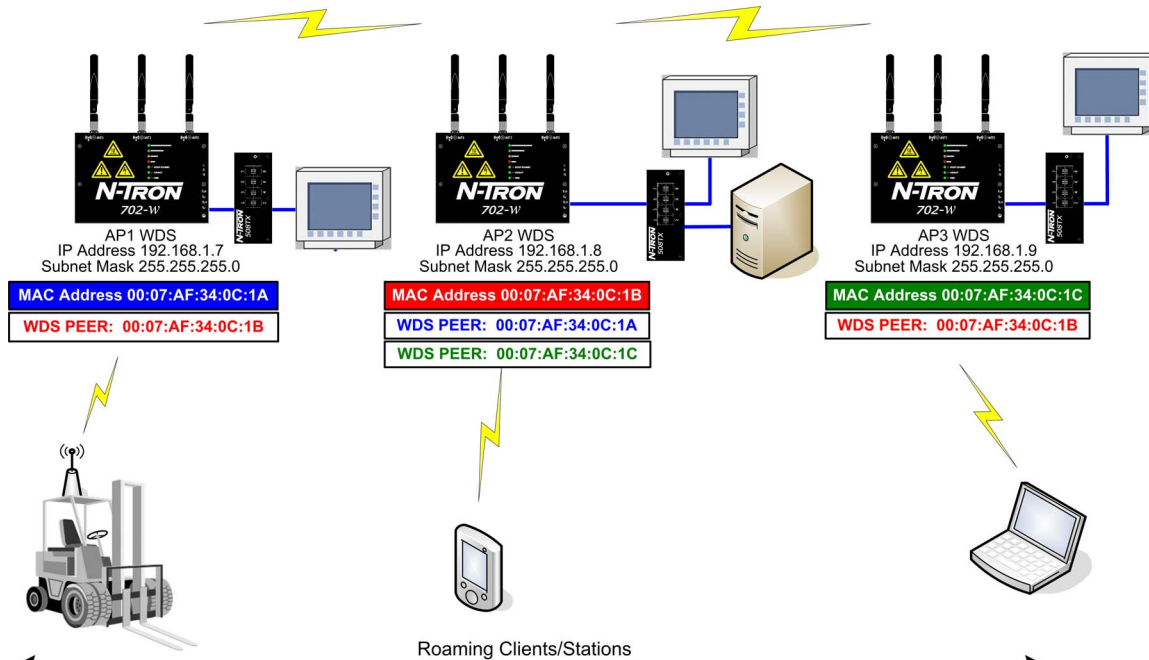

The 702-Ws have been configured as peers. This allows forklifts or other mobile wireless device to maintain communication as they move from the area covered by one 702-W into the area covered by the next 702-W.

## Scenario 4 – Broadband Modem Wireless Router (W/ DHCP)

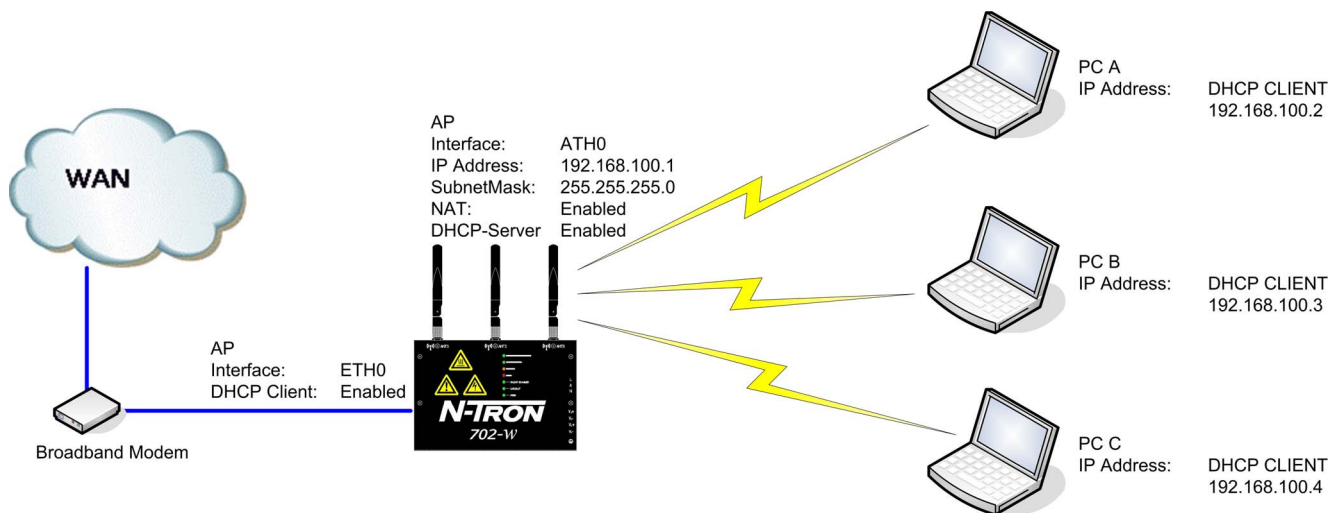

N-TRON 702-W configured as a powered Router allows layer 3 routing to set up network segmentation. It supports the Network Address Translation (Masquerading) feature which is widely used by Access Points. NAT will act as the firewall between LAN and WLAN networks. Additional Firewall settings can be configured for Layer 3 packet filtering and access control in Router mode. It can also act as a DHCP server, automating the assigning of IP addresses.

## 702-W Specifications

### Physical

Height: (w/o antennas)	5.2"	(13.2cm)
Width:	7.4"	(18.8cm)
Depth (incl. DIN-Rail mount):	1.5"	(3.81cm)
Weight (max):	1.9 lbs	(0.86kg)
DIN-Rail Mount:	35mm	

### Environmental

Operating Temperature:	-40°C to 70°C
Storage Temperature:	-40°C to 85°C
Operating Humidity:	5% to 95% (Non Condensing)
Operating Altitude:	0 to 10,000 ft.
N-TRON Power Supply:	NTPS-24-1.3

### Electrical

Redundant Input Voltage:	20-49 VDC (Regulated)
Input Current (max):	200mA max @24 VDC
702-W Max Power:	4.8Watts max
Input Ripple:	Less than 100mV

### Reliability

MTBF:	>1 Million Hours
-------	------------------

### Network Media

10BaseT:	>Cat3 Cable
100BaseTX:	>Cat5 Cable
802.11abgn:	Air

### Connectors

10/100BaseTX:	One (1) RJ-45 Copper Port PoE Powered device support
802.11abgn	(3) RP-SMA connectors

### Recommended Wiring Clearance (Antenna Dependent)

Front:	4" (10.16cm)
Side:	4" (10.16cm)
Top:	6" (15.24cm)

## 702-W WIRELESS ETHERNET RADIO

### Ordering Information

<b>702-W</b>	Industrial Wireless Radio
<b>702-W-PM</b>	Panel Mount Kit for 702-W
<b>ANT-CAB-400-N-RPTNC-X</b>	Low Loss Coaxial Antenna cable; 1 RP-SMA and 1 N Male connector
<b>ANT-MD24-12</b>	2.4GHz 12dBi Mini Directional Antenna
<b>ANT-PD58-32</b>	5.8 GHz Parabolic Dish 32dBi Directional Antenna
<b>M12-DRK</b>	DIN-Rail kit for 702M12-W
<b>NTPS-24-1.3</b>	DIN-Rail Power Supply 24V@1.3 Amp

### Radio Output Power:

Up to 250mW US

<b>802.11a 5GHz</b>	
DataRate	Avg TX ±2dB
1-24Mbps	24 dBm
36Mbps	22 dBm
48Mbps	20 dBm
54Mbps	19 dBm

<b>802.11b/g 2.4GHz</b>	
DataRate	Avg TX ±2dB
1-24Mbps	24 dBm
36Mbps	22 dBm
48Mbps	20 dBm
54Mbps	19 dBm

<b>802.11n 2.4GHz 5GHz</b>		
DataRate	Avg TX ±2dB	
MCS0	24dBm	24dBm
MCS1	24dBm	24dBm
MCS2	24dBm	24dBm
MCS3	22dBm	22dBm
MCS4	22dBm	22dBm
MCS5	22dBm	22dBm
MCS6	18dBm	18dBm
MCS7	15dBm	15dBm
MCS8	24dBm	24dBm
MCS9	24dBm	24dBm
MCS10	22dBm	22dBm
MCS11	20dBm	20dBm
MCS12	20dBm	20dBm
MCS13	17dBm	17dBm
MCS14	17dBm	17dBm
MCS15	15dBm	15dBm

### Radio Receiver Sensitivity

<b>802.11a 5GHz</b>	
DataRate	Sens. ±3dB
1-24Mbps	-96 dBm
36Mbps	-95 dBm
48Mbps	-84 dBm
54Mbps	-91 dBm

<b>802.11b/g 2.4GHz</b>	
DataRate	Sens. ±3dB
1-24Mbps	-97 dBm
36Mbps	-90 dBm
48Mbps	-86 dBm
54Mbps	-84 dBm

<b>802.11n 2.4GHz 5GHz</b>		
DataRate	Sens. ±3dB	
MCS0	-97dBm	-96dBm
MCS1	-96dBm	-95dBm
MCS2	-93dBm	-92dBm
MCS3	-91dBm	-90dBm
MCS4	-87dBm	-86dBm
MCS5	-84dBm	-83dBm
MCS6	-78dBm	-77dBm
MCS7	-75dBm	-74dBm
MCS8	-96dBm	-95dBm
MCS9	-94dBm	-93dBm
MCS10	-91dBm	-90dBm
MCS11	-88dBm	-87dBm
MCS12	-85dBm	-84dBm
MCS13	-80dBm	-79dBm
MCS14	-79dBm	-78dBm
MCS15	-76dBm	-75dBm

### Regulatory Approvals

UL /cUL Class I, Div 2, Groups A, B, C, D, and T4A  
ANSI/ISA-12.12.01-2007 and UL 508 and 1604  
FCC/CE (CFR 47, Part 15, Subpart B - Class A)  
EN 301 489-3, IEC 6100-4-2, 6100-4-3,  
R&TTE Directive 99/5/EC, ANSI C63.4, and ICES-003 Issue 3  
GOST-R Certified, RoHS Compliant

Designed to comply with:  
IEEE 1613 for Electric Utility Substations  
NEMA TS1/ TS2 for Traffic control

### Contact Information

**N-TRON Corp.**  
820 S. University Blvd., Suite 4E  
Mobile, AL 36609 USA  
TEL: (251) 342-2164  
FAX: (251) 342-6353  
Website: [www.n-tron.com](http://www.n-tron.com)  
Email: [N-TRON\\_info@n-tron.com](mailto:N-TRON_info@n-tron.com)

**N-TRON Europe GmbH**  
Alte Steinhäuserstr 19  
6330 Cham / Zg Switzerland  
TEL: +41 41 7406636  
FAX: +41 41 7406637

REV 090803

